



Schienenwege – Schienen- und Brückendämpfung



Dr.-Ing. Christoph Gramowski
Schrey & Veit GmbH



Inhalt



Schienendämpfer



Brückenabsorber

Radabsorber

Zusammenfassung

Einflüsse

Erfahrungen

Dringend:
Anerkennung



Schienendämpfer – Einflüsse

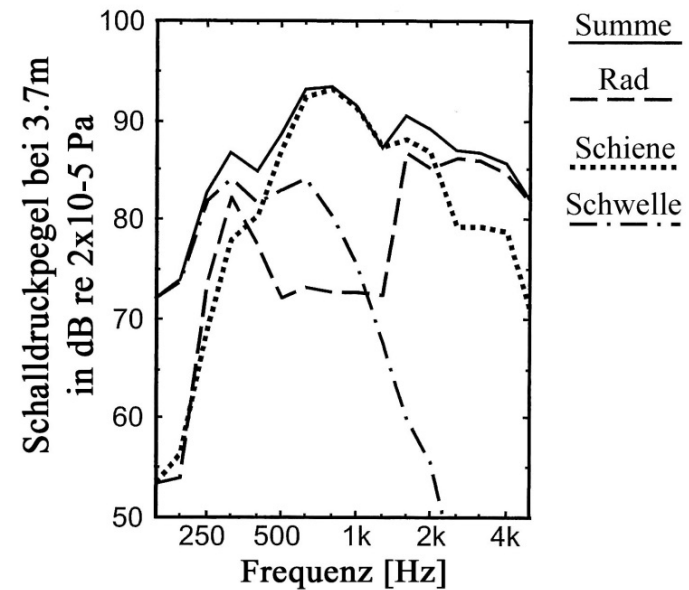
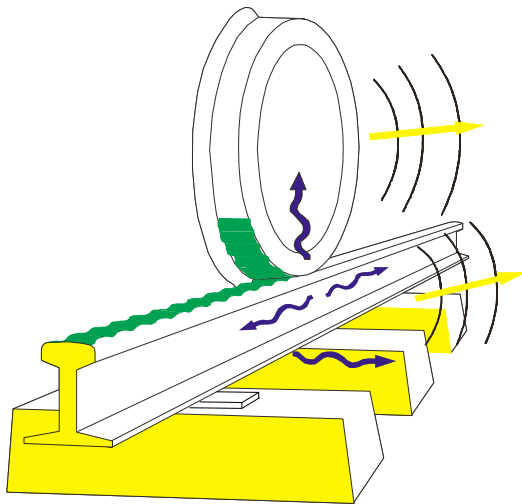

Bahnlärm – W W W :

Wer strahlt Wann in Welchem Frequenzbereich ab?



Schienendämpfer – Einflüsse

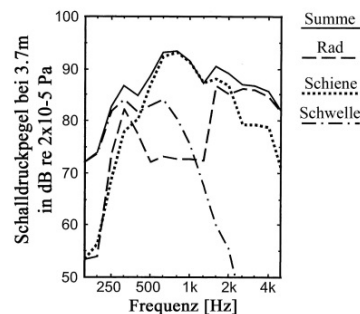
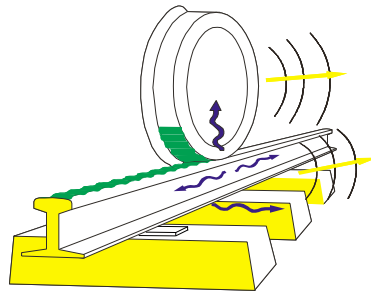

Wer?

Schiene (Schwelle)

Wann?

- Fremdgeräusche
- Radrauheiten

- Kein Antriebsgeräusch
- Unabhängig von Bremsklotzbauart

Welche Frequenz?

Bekannt für Schiene und Schwelle



Schienendämpfer – Erfahrungen

Zugart	Reduktion (Mittelwert)
Güterzug	1 – 4 dB
IC / ICE	1 – 3 dB
Regio / S-Bahn	1 – 3 dB

DB Netz: Messungen im KPII

Noch notwendig:
Kombination mit nSSW, HSG,
Erschütterungsschutz ...

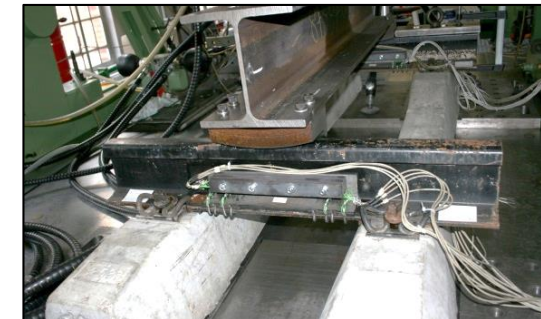
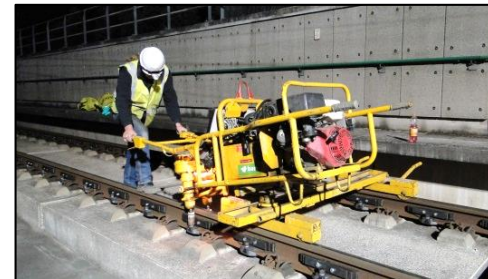



Schienendämpfer – Erfahrungen

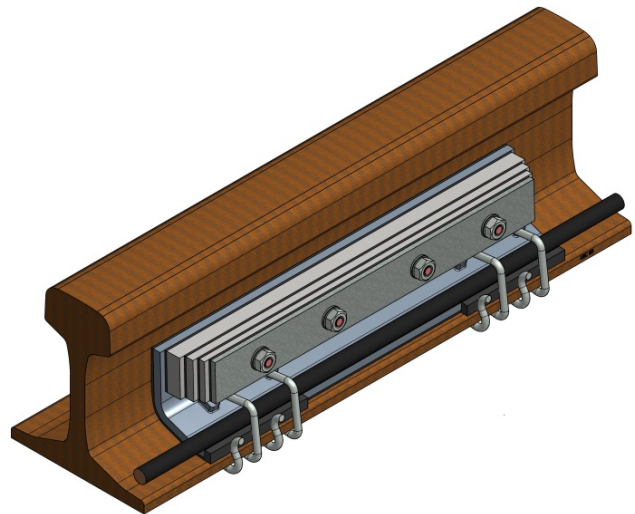

VICON AMSA VS

Vorteile Federbefestigung

- Elastisch → Dauerhafte Kraftvorhaltung
- Stopfarbeiten uneingeschränkt möglich
- Weniger Bauteile
- Mindestens gleiche Montagegeschwindigkeit
- Keine funktionalen Nachteile gegenüber der Schraubbefestigung



Relativ zu KP II: Geringere Instandhaltungskosten, aber: ...nächste Folie...



Schienendämpfer – Dringend: Anerkennung

Gesetzliche Anerkennung

Schall03 [201X]



DB interne
Produktzulassung /
-anerkennung

EBA-Zulassung
für Regelbetrieb

Lärmsanierung

Lärmprognose bei PFV

Technologie

Produkt



Brückenabsorber - Einflüsse

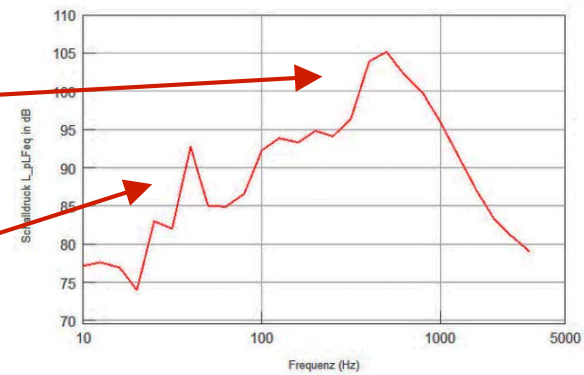
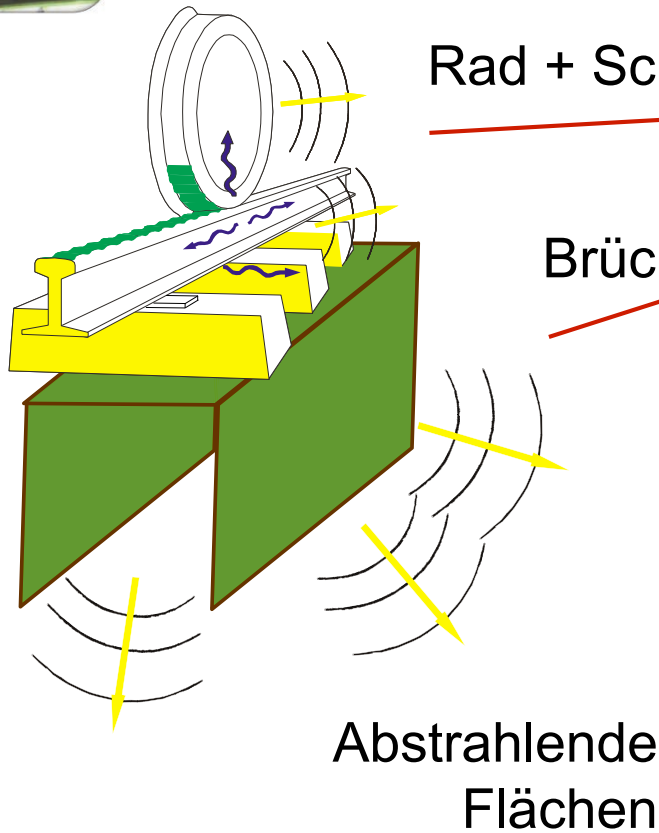



Brückenabsorber - Einflüsse

Konstruktions-
prinzip

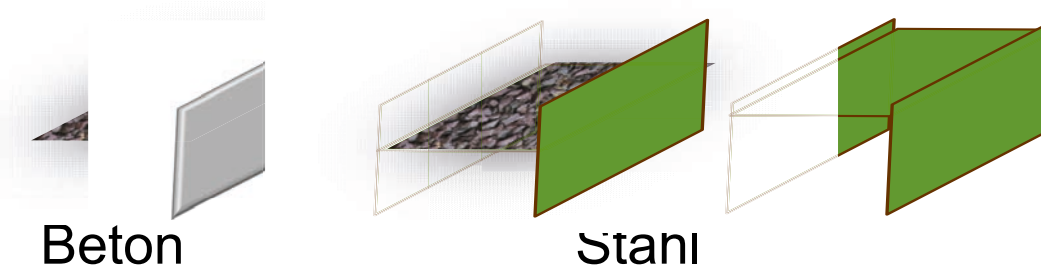

Beton

Stahl

Schall03 [2012]

+ 3

+ 6

+ 12 dB

Ausbreitung

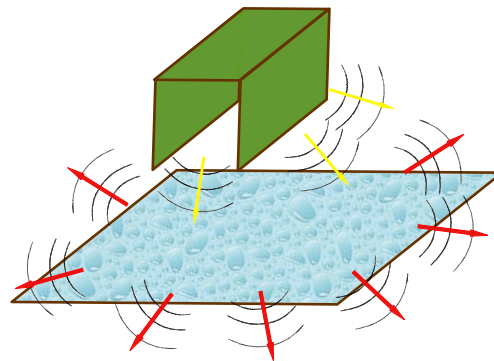

EBA Lärmkartierung



Brückenabsorber - Erfahrungen

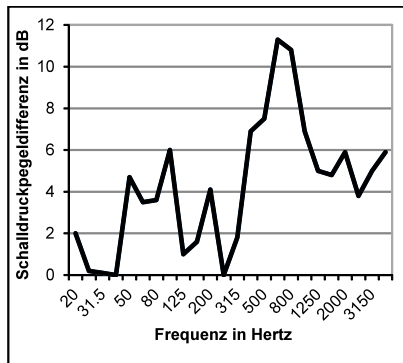

SNCF / F. Poisson

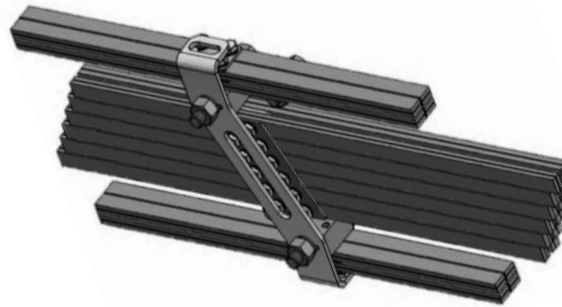

Montage ohne
Gleissperrung

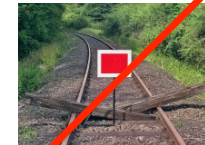



Brückenabsorber - Erfahrungen

Kombination mit weiteren Maßnahmen

- Weichere (elastische) Stützpunkte → Schienendämpfer
- Elastische Schwellenlagerung
- Verlegung des Schienenauszeuges in den Dammbereich

Ziel: Reduktion des Schwingungseintrages in die Brückenkonstruktion

→ Technologien vorhanden, weitere Untersuchungen notwendig

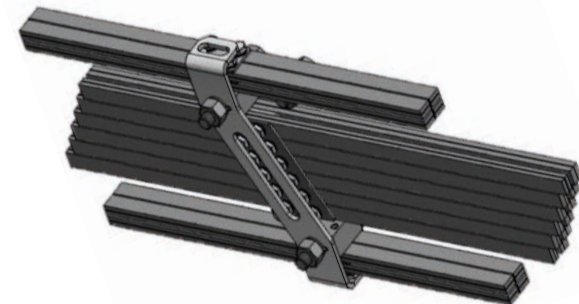



Brückenabsorber – Dringend: Anerkennung

Gesetzliche Anerkennung

Schall03 [201X]

DB interne
Produktzulassung /
-anerkennung

Indiv. Brücken-
Konstruktion

Lärmsanierung

Lärmprognose bei PFV

Technologie

Produkt



Radabsorber

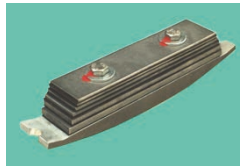
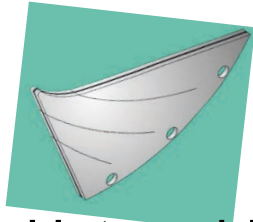

Unterschiedliche Entwicklungen

LZarG

Gefördert durch das



Bundesministerium für Wirtschaft und Technologie



EBA

TSI

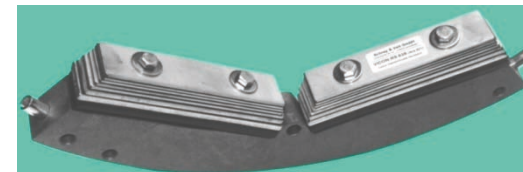

Ringsegment mit Blockabsorber



BA308

Zusammenfassung



Schienenendämpfer

***Viel Erfolg und
vielen Dank für Ihre Aufmerksamkeit***

Optimierte Technologie

Lärminderung ohne Sichtbehinderung

Verschiedene Einflüsse (Fzg., Gleis, Betrieb)

Dringend: Anerkennung ‚Schutzmaßnahme‘



Brückenabsorber

Erprobte Technologie gegen ‚Dröhnen‘

Einbau ohne Gleissperrung

Dringend: Anerkennung ‚Schutzmaßnahme‘



Radabsorber

Erprobte Technologie im Nahverkehr

Volle Zulassung im Güterverkehr

Dringend: Anwendung